



Performance Under Pressure

PARTS LIST FOR
JCW-2703-0MHB/IB/RB
(AFTER SERIAL #10070000)

Engine Oil Grade:

Honda/Subaru:

SAE 10W-30

Inteck I/C:

Above 40°F=SAE 30

Below 40°F=SAE10W-30

Engine Oil Capacity:

20 oz.

Pump Oil Grade:

Mi-T-M Pump Oil #AW-4085-0016

Pump Oil Capacity:

14 oz.

Nozzle Size:

3.0

This Parts Listing has been compiled for your benefit. You can be assured your Mi-T-M Cold Water Pressure Washer was constructed and designed with quality and performance in mind using over 25 years experience in the pressure washer business. Each component has been rigorously tested to insure the highest level of acceptance.

The contents of this Parts Listing are based on the latest product information available at the time of publication. Mi-T-M reserves the right to make changes in price, color, materials, equipment, specifications or models at any time without notice.

WARNING

THIS IS A PROFESSIONAL HIGH PRESSURE, COLD WATER PRESSURE WASHER. CAUTION SHOULD BE OBSERVED WHEN USING OR REPAIRING THIS UNIT! READ AND FOLLOW THE SAFETY WARNINGS LISTED BELOW BEFORE ATTEMPTING ANY REPAIRS ON THIS PRESSURE WASHER!

SAFETY WARNINGS

1. NEVER alter or modify the equipment. Be sure any accessory items and system components being used will withstand the pressure developed. Use only genuine Mi-T-M parts for repair of your pressure washer. Failure to do so can cause hazardous operating conditions and will VOID warranty.
2. NEVER make adjustments on machinery while the unit is connected to the engine without first removing the ignition cables from the spark plugs. Turning over the machinery by hand during adjustment or cleaning might start the machinery, causing serious injury to the operator.
3. Know how to stop and bleed pressures quickly. Be thoroughly familiar with controls.
4. Before servicing the unit, turn unit off, relieve the water pressure and allow the unit to cool down. Do not make repairs while the unit is running. Service in a clean, dry, flat area.
5. After testing the machine, DO NOT leave the pressurized unit unattended. Shut off the unit and release trapped pressure before leaving.

Table of Contents

SPECIFICATIONS	3
FRAME ASSEMBLY (AFTER SERIAL #10070000)	4
PUMP ASSEMBLY (3-0228)	6
UNLOADER ASSEMBLY (8-0456)	8
GUN ASSEMBLY (16-0001)	10

SPECIFICATIONS

MODEL NUMBER	JCW-2703-0MHB	JCW-2703-0MIB	JCW-2703-0MRB
Operating Pressure (PSI/Bar):	2700/186		
High Pressure Nozzle:	3.0		
Water Volume (GPM/lpm):	2.4/9.0		
Engine:	Honda	Intek I/C	Subaru
Horsepower	6.5		7.0
Engine Type	4 Stroke, Overhead Valve, Single Cylinder		
Oil Type	SAE10W-30	Above 40°F = SAE30/Below 40°F = SAE10W-30	SAE10W-30
Oil Capacity (oz./liters)	20/6		
Low Oil Protection	Oil Alert™	Oil Guard™	Oil Sensor
Fuel Type	Unleaded Gasoline 86 Octane Minimum		
Fuel Capacity (gallon/ liters)	.95/3.6	.75/2.85	.95/3.6
Starting	Recoil		
Maximum No Load RPM	3600		
Pump:	Belt Driven, Oil Bath, Triplex Piston		
Oil Type	Mi-T-M Pump Oil #AW-4085-0016		
Oil Capacity (oz./liters)	14/41		
Plungers	Ceramic		
Manifold	Forged Brass		
Valves	Stainless Steel		
Unloader	Adjustable		
Thermal Relief Valve	Relieves heated water during unloader bypass stage		
Unit Net Weight (lbs/Kg)	124/56	123/56	124/56
Unit Shipping Weight (lbs/Kg)	174/79	173/78.5	174/79
Unit Net Dimension (in/cm)	37.5Lx22Wx25H/95.25Lx56Wx63.5H		
Unit Shipping Dimension (in/cm)	40Lx26Wx34H/101Lx66Wx86H		

FRAME ASSEMBLY (AFTER SERIAL #10070000)

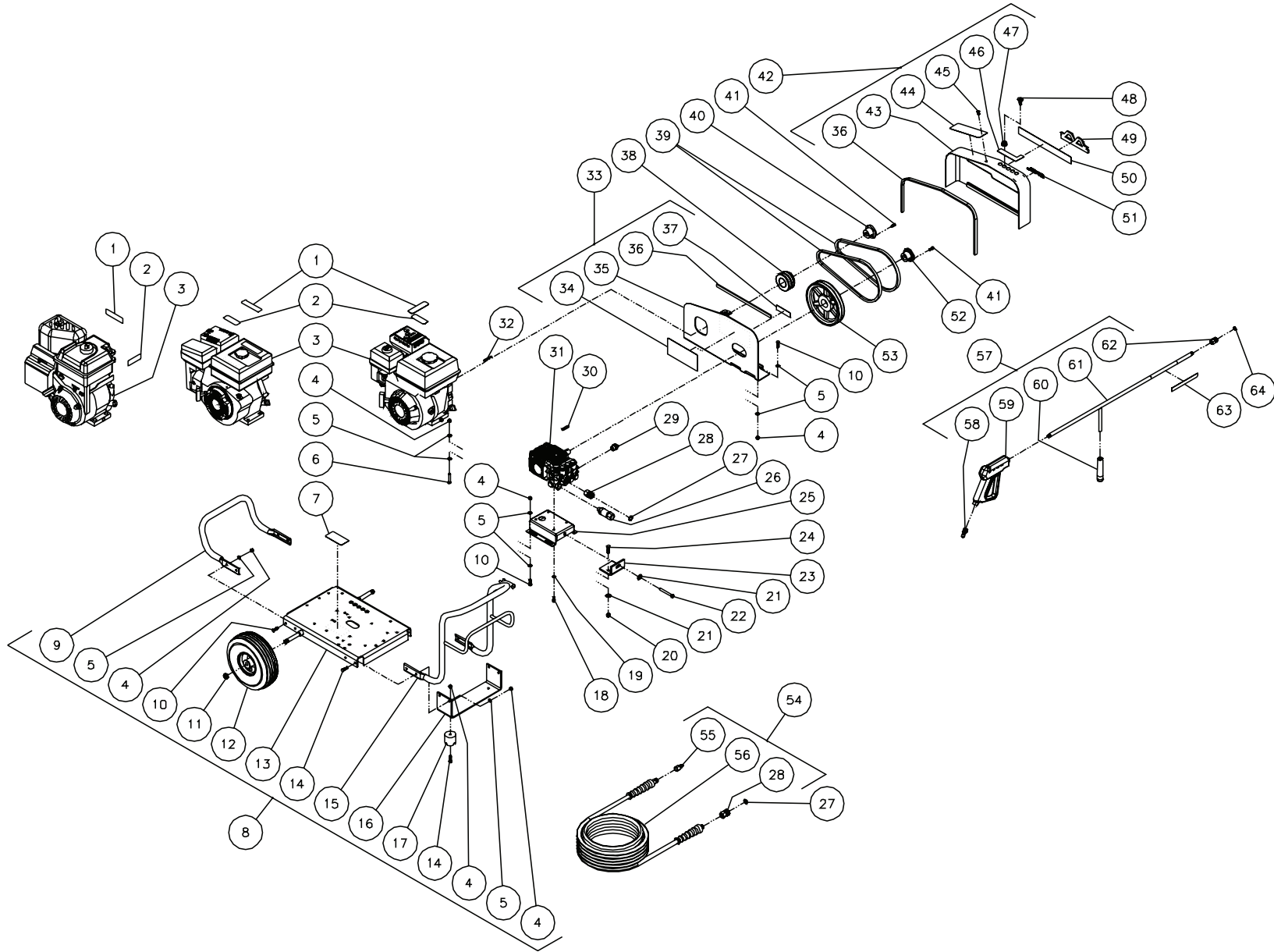

JCW-2703-0MHB/N/R-122702-DLG

FRAME ASSEMBLY (AFTER SERIAL #10070000)												
REF #	DESCRIPTION	PART #	QTY	REF #	DESCRIPTION	PART #	QTY	REF #	DESCRIPTION	PART #	QTY	
1	Decal- Caution: Risk of Fire (See 34-9017)	N/A Sep.	1	23	Angle Tightener Bracket	13-0005A01	1	47	Grommet	33-0001	5	
2	Decal- Warning: Risk of Burns (See 34-9017)	N/A Sep.	1	24	Bolt	27-0118	2	48	Nozzle- 0003	18-0302	1	
3	Engine- Honda 6.5 HP (JCW-2703-0MHB)	1-0088	1	25	Pump Bracket	5-0133A01	1	-	Nozzle- 1503	18-0150	1	
-	Engine- Intek 6.5 HP (JCW-2703-0MIB)	1-0109	1	26	Inlet Filter	19-0206	1	-	Nozzle- 2503	18-0303	1	
-	Engine- Subaru 7.0 HP (JCW-2703-0MRB)	1-0133	1	27	O-ring	25-0123	2	-	Nozzle- 4003	18-0304	1	
4	Locknut	30-0157	22	28	Socket	17-0004	2	49	Decal- Mi-T-M Small Logo	62-0086	1	
5	Flatwasher	28-0023	32	29	Thermal Relief Valve	22-0005	1	50	Decal- Mi-T-M Stripe	34-0502	1	
6	Bolt	27-0070	4	30	Key w/ Pump	43-0091	1	51	Decal- White Die Cut 2700PSI	34-0774	1	
7	Decal- Data Plate	N/A	1	31	Pump	3-0228	1	52	Bushing	9-0017	1	
8	Base Assembly (Inc. 4, 5, 9-17)	851-0212	1	32	Key	43-0073	1	53	Sheave	10-0007	1	
9	Rear Handle	7-0103A01	1	33	Beltguard Back Assembly (Inc. 34-37)	851-0213	1	54	Hose Assembly (Inc. 28, 55, 56)	851-0007	1	
10	Bolt	27-0067	12	34	Decal- Warning/Caution (See 34-9017)	N/A Sep.	1	55	Quick Connect Plug	17-0006	1	
11	Nut	30-0117	2	35	Beltguard Back Assembly (See 851-0213)	N/A Sep.	1	56	Hose	15-0003	1	
12	Wheel	14-0017	2	36	Edging *(Four Feet Required)	33-0020	1	57	Gun/Wand Assembly (Inc. 58-62)	851-0095	1	
13	Baseplate	5-0184A01	1	37	Decal- Warning: Beltguard (See 34-9017)	N/A Sep.	1	58	Quick Connect Plug	17-0005	1	
14	Bolt	27-0068	6	38	Sheave	10-0029	1	59	Trigger Gun	16-0001	1	
15	Front Handle	7-0100A01	1	39	Belt	11-0031	2	60	Wand Grip	7-0002	1	
16	Underbracket	13-0002A01	1	40	Bushing	9-0009	1	61	Wand	16-0120A01	1	
17	Isolator	14-0008	2	41	Bolt	27-0015	4	62	Quick Connect Socket	17-0001	1	
18	Bolt	27-8884	4	42	Beltguard Cover Assembly (Inc. 37, 43-47)	851-0313	1	63	Decal- Warning: Risk of Injection (See 34-9017)	N/A Sep.	1	
19	Lockwasher	29-0054	4	43	Beltguard Cover (See 851-0313)	N/A Sep.	1	64	O-ring	25-0122	1	
20	Locknut	30-0159	2	44	Decal- Operation (See 34-9017)	N/A Sep.	1		Safety Decal Kit (Inc. 1-2, 34, 37, 44, 63)	34-9017		
21	Flatwasher	28-0023	3	45	Fastener	33-0197	1	*Must Order in One Foot Lengths				
22	Bolt	27-0576	1	46	Decal- Nozzles 0, 15, 25, 40	34-0500	1					

PUMP ASSEMBLY (3-0228)

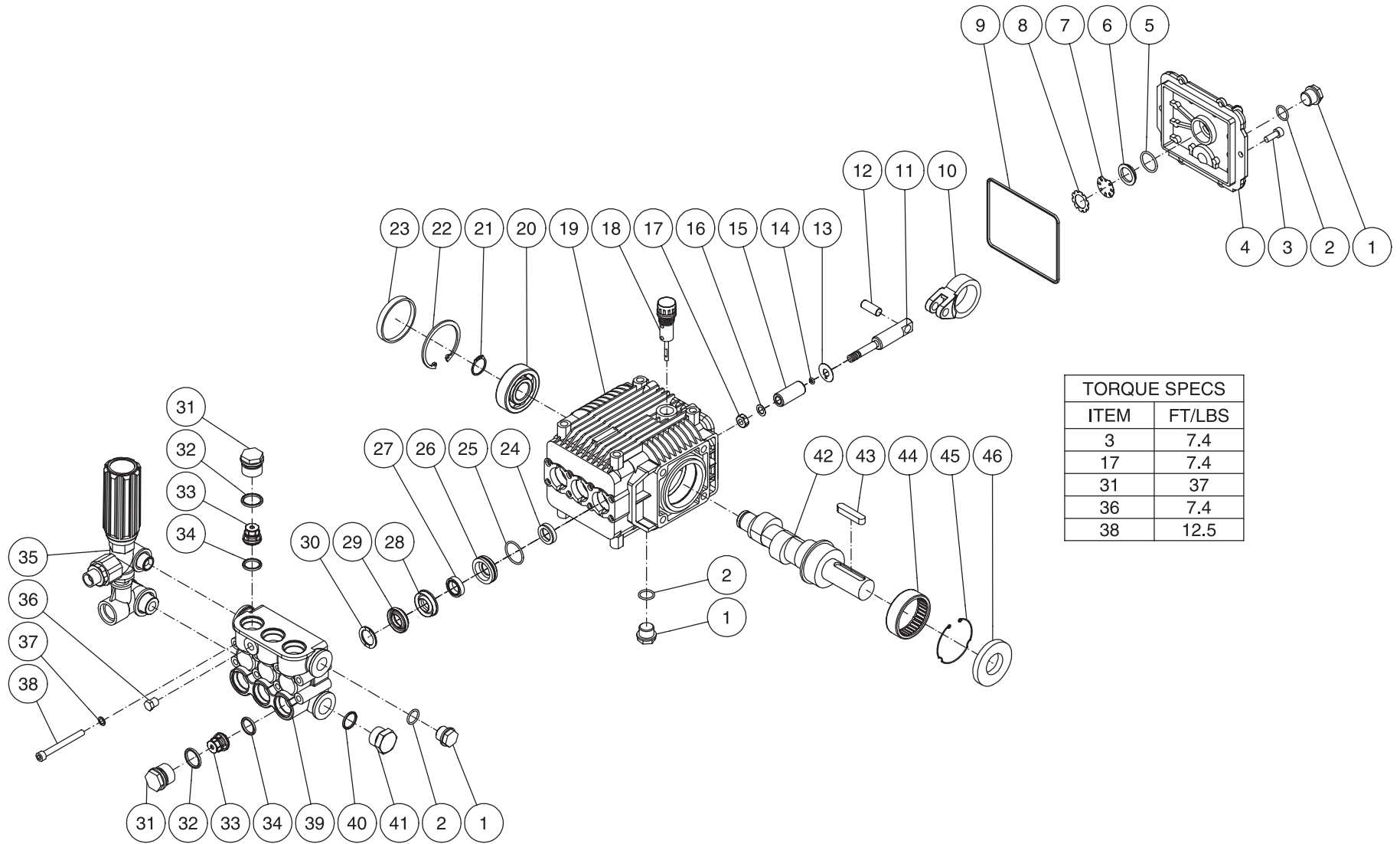

TORQUE SPECS	
ITEM	FT/LBS
3	7.4
17	7.4
31	37
36	7.4
38	12.5

3-0228-080905-JJT

PUMP ASSEMBLY (3-0228)							
REF. #	DESCRIPTION	PART #	QTY.	REF. #	DESCRIPTION	PART #	QTY.
1	Plug	39-0086	3	26	Retainer	46-0726	3
2	O-ring	25-0325	3	27	Low Pressure Seal (See 70-0181)	N/A Sep.	3
3	Bolt	27-8888	6	28	Packing Retainer	46-0728	3
4	Crankcase Cover	46-0719	1	29	V-Packing (See 70-0181)	N/A Sep.	3
5	O-ring	25-0370	1	30	Support Ring (See 70-0182)	N/A Sep.	3
6	Oil Sight Glass	46-0670	1	31	Valve Cap	39-0087	6
7	Reflector	46-0824	1	32	O-ring	25-0160	6
8	Retainer	46-0671	1	33	Single Valve Assembly (See 70-0161)	N/A Sep.	6
9	O-ring	25-0398	1	34	O-ring	25-0386	6
10	Connecting Rod	46-0720	3	35	Unloader	8-0456	1
11	Plunger Rod	46-0722	3	36	Plug	39-0097	1
12	Piston Pin	46-0721	3	37	Lockwasher	29-0153	8
13	Washer	28-1027	3	38	Bolt	27-8875	8
14	O-ring	25-0371	6	39	Manifold	46-0730	1
15	Piston	46-0723	3	40	O-ring	25-0372	1
16	Washer	26-0187	3	41	Plug	39-0088	1
17	Nut	30-6016	3	42	Crankshaft	46-0754	1
18	Oil Dipstick	39-0090	1	43	Key	43-0091	1
19	Crankcase	46-0724	1	44	Bearing	48-0059	1
20	Bearing	48-0063	1	45	Retaining Ring	46-0667	1
21	Retaining Ring	46-0732	1	46	Oil Seal	26-0250	1
22	Retaining Ring	46-0676	1		High Pressure Seal Kit (Inc. 3 each 25, 27, 29)	70-0181	
23	Bearing Cap	46-0725	1		Support Ring Kit (Includes 3 each 30)	70-0182	
24	Oil Seal	N/A	3		Valve Kit (Includes 6 each 33)	70-0161	
25	O-ring	25-0399	3				

UNLOADER ASSEMBLY (8-0456)

TORQUE SPECIFICATIONS	
POSITION	FT.-LBS
9	25.8
20	18.5
25	18.5
28	18.5
33	25.8

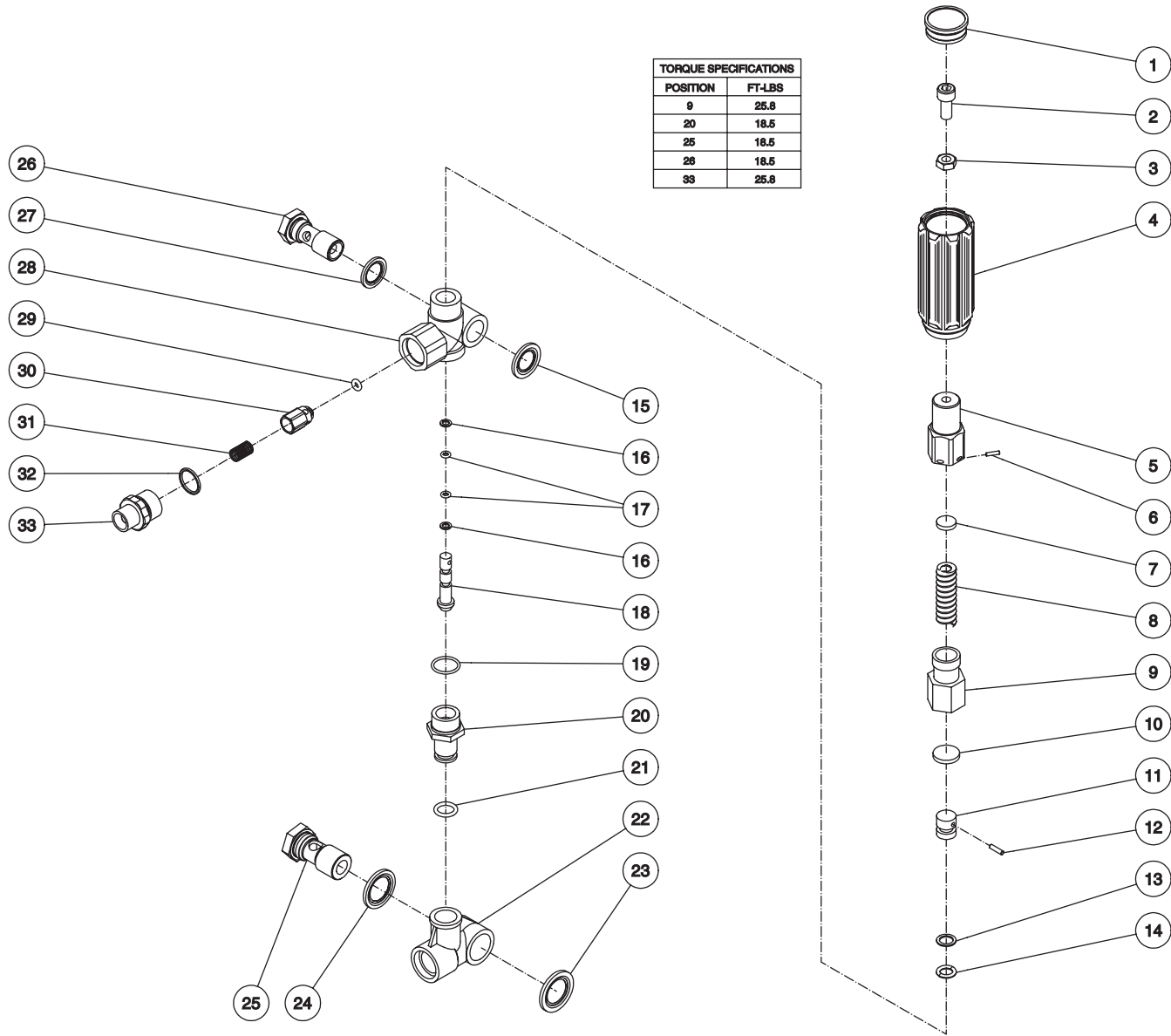

UNLOADER ASSEMBLY (8-0456)							
REF. #	DESCRIPTION	PART #	QTY.	REF. #	DESCRIPTION	PART #	QTY.
1	Unloader Cap	7-0142	1	18	Piston	8-0442	1
2	Bolt	27-8433	1	19	O-ring	25-0389	1
3	Nut	30-3025	1	20	Nipple	8-0441	1
4	Unloader Knob	7-0141	1	21	O-ring	25-0388	1
5	Adjustment Barrel	8-0476	1	22	Inlet Bypass Adapter	8-0437	1
6	Pin	8-0477	1	23	Washer	8-0439	1
7	Spring Button	8-0475	1	24	Washer	8-0440	1
8	Spring	49-0132	1	25	Adapter	8-0438	1
9	Spring Guide	8-0474	1	26	Adapter	8-0448	1
10	Spring Button	8-0445	1	27	Washer	8-0449	1
11	Poppet	8-0443	1	28	Unloader Body	8-0451	1
12	Pin	8-0444	1	29	O-ring	25-0391	1
13	Back-up Ring	25-0396	1	30	Check Valve	8-0454	1
14	O-ring	25-0390	1	31	Check Valve Spring	49-0123	1
15	Washer	8-0450	1	32	O-ring	25-0372	1
16	Back-up Ring	25-0395	2	33	Adapter Nipple	24-0159	1
17	O-ring	25-0371	2		Unloader Repair Kit (Inc. 13, 14, 16, 17, 19, 21, 29)	70-0180	

GUN ASSEMBLY (16-0001)

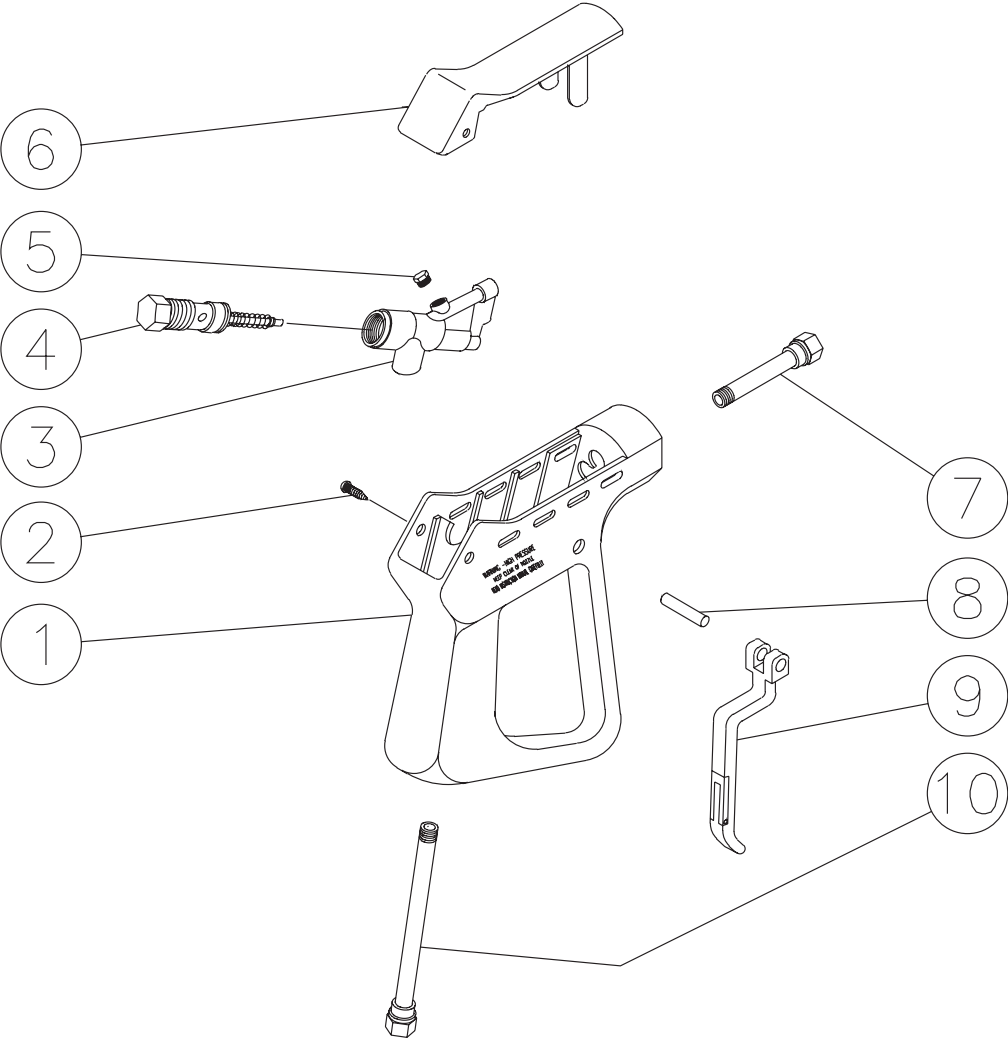

GUN ASSEMBLY (16-0001)			
REF. #	DESCRIPTION	PART #	QTY.
1	Plastic Housing	16-0008	1
2	Screw	27-3230	2
3	Brass Housing	16-0012	1
4	Gun Repair Kit	70-0055	1
5	Brass Plug	39-0024	1
6	Plastic Cover	16-0009	1
7	Pipe Assembly	16-0013	1
8	Trigger Pin	16-0063	1
9	Trigger/Safety Lock-off	16-0010	1
10	Pipe Assembly- Inlet	16-0016	1
	Complete Gun Assembly	16-0001	1

Manufactured by Mi-T-M
8650 Enterprise Drive, Peosta IA 52068
563-556-7484/ Fax 563-556-1235